

ALCOR

# CANALES DE ANCLAJE

para fijaciones regulables en hormigón

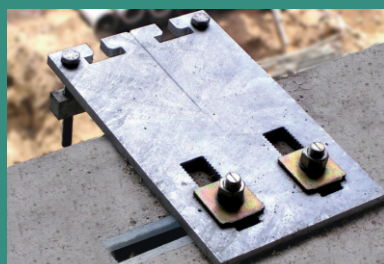
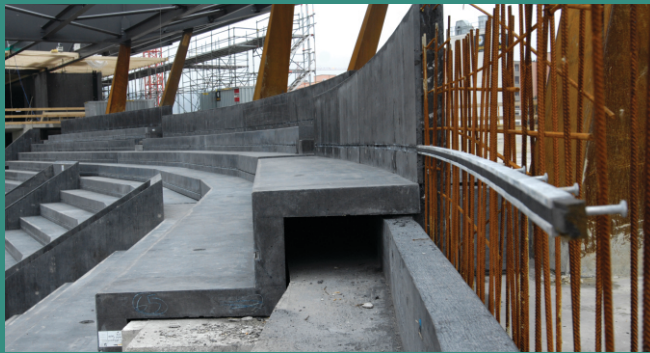
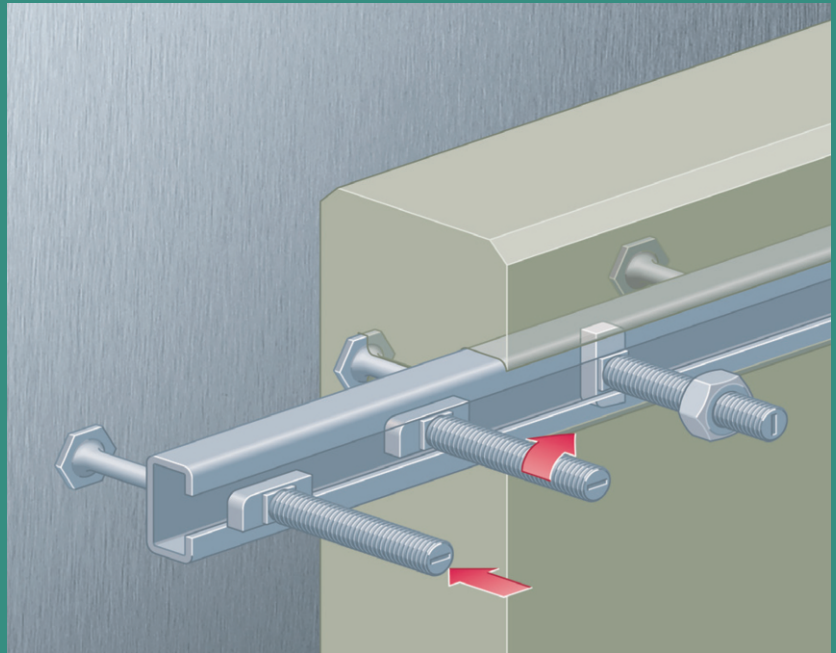

  
**HALFEN**  
A CRH COMPANY

# Canales de Anclaje

## La solución óptima para todo tipo de fijaciones regulables

- Reduce notablemente los tiempos de instalación en obra.
- No produce daños en la armadura ni en el hormigón.
- Permite distancias mínimas al borde gracias a la posibilidad de instalar armaduras adicionales.
- Fijación regulable. Las instalaciones se pueden ajustar libremente a lo largo de la ranura del canal, compensando errores de montaje.
- El instalador utiliza herramientas simples y sin energía eléctrica. No requiere entrenamiento especial.
- Protegidos de la corrosión por galvanizado en caliente o fabricados íntegramente en acero inoxidable.
- Canales dentados laminados en caliente con alta resistencia a cargas longitudinales, dinámicas, de impacto y sísmicas.
- Control de calidad rápido y sencillo. Solo debe realizarse una inspección visual a la posición de la ranura que presenta el bulón en su extremo visto.

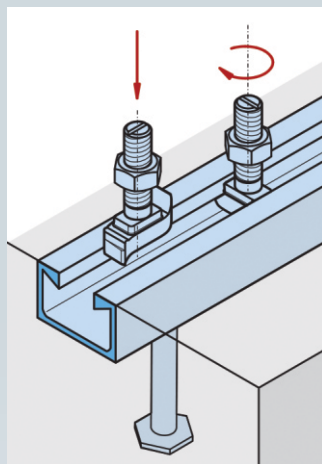

Rápida instalación

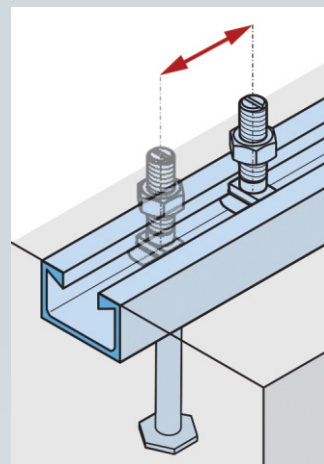

Amplio registro

## Aplicaciones en Muro Cortina

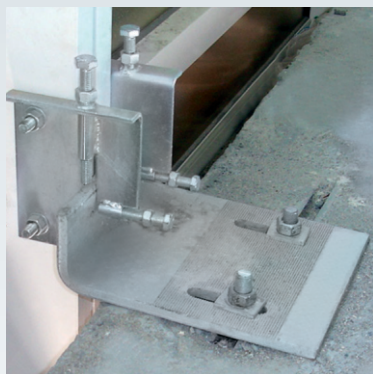

Sistema sobre losa (TOS)

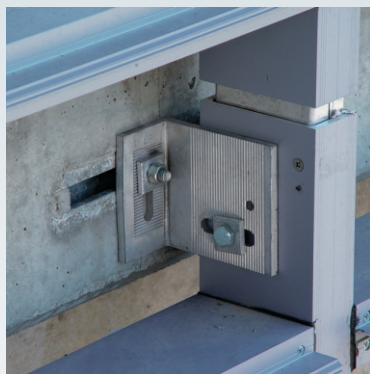

Sistema en canto de losa (FOS)



Sistema combinado

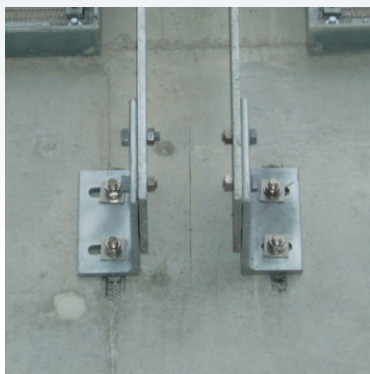

Canales dentados instalados verticalmente

## Otras aplicaciones

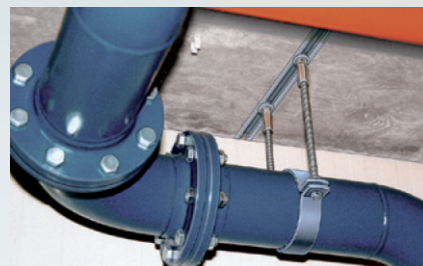

Instalación de tuberías

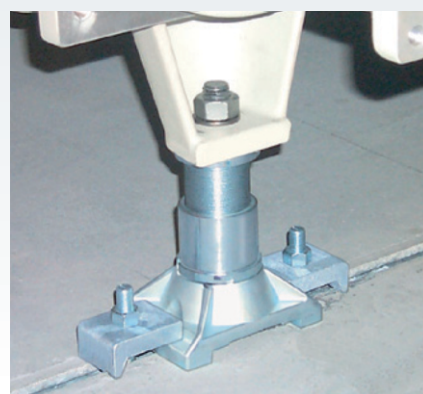

Fijación de maquinarias



Fijación de elementos premoldeados

# Canales de Anclaje laminados en frío

Modelo	HTA-CE 28/15	HTA-CE 38/17	HTA-CE 40/25	HTA-CE 49/30	HTA-CE 54/33	
Referencias geométricas						
Bulón	HS 28/15	HS 38/17	HS 40/22	HS 50/30	HS 50/30	
Rosca	M6 – M12	M10 – M16	M10 – M16	M10 – M20	M10 – M20	
S <sub>slb</sub> [mm]	42	52	65	81	88	
<b>Capacidad de carga</b>						
N <sub>Rd,s,l</sub> [kN]	5,0	10	11,1	17,2	30,6	
V <sub>Rd,s,l</sub> [kN]						
M <sub>Rd,s,flex</sub> [Nm]	Acero	276	504	956	1455	2595
	Inox.	282	516	931	1485	2595
<b>Geometría</b>						
h <sub>inst</sub> [mm] <sup>(1) (2)</sup>	50 (79)	81 (82)	89 (89)	103 (101)	161 (164)	
b <sub>ch</sub> [mm]	28	38	40	50	54	
h <sub>ch</sub> [mm]	15,25	17,5	25	30	33	
I <sub>y</sub> [mm <sup>4</sup> ]	Acero	4060	8547	20570	41827	72079
	Inox.			19097		
h <sub>ef</sub> [mm]	45	76	79	94	155	
c <sub>min</sub> [mm]	40	50	50	75	100	
La capacidad de carga del hormigón debe verificarse para cada caso individual						
c <sub>min</sub> : distancia mínima a borde del hormigón			N <sub>Rd,s,l</sub> : capacidad de carga del labio del canal (tracción)			
S <sub>slb</sub> : distancia axial entre bulones para N <sub>Rd,s,l</sub>			V <sub>Rd,s,l</sub> : capacidad de carga del labio del canal (corte)			
<sup>(1)</sup> Altura nominal			<sup>(2)</sup> (Valor para anclajes soldados I)			
<b>Material / Acabado:</b> fv: Acero S235JR Galvanizado en caliente · A4: Acero inoxidable W 1.4571/1.4404 · HCR: Acero inoxidable W 1.4529/1.4547						

HTA-CE laminado en frío



Tracción céntrica FZ  
Tracción transversal FQ

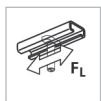

Tracción longitudinal FL  
(cargas pequeñas)

HTA-CE laminado en caliente

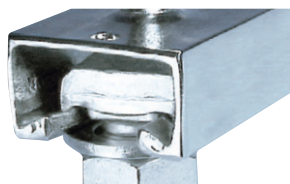

Tracción céntrica FZ  
Tracción transversal FQ

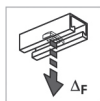

Cargas dinámicas con  
amplitud de carga ΔF

HZA DYNAGRYP laminado en caliente (labios dentados)

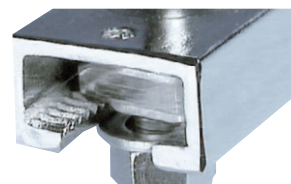

Tracción céntrica FZ  
Tracción transversal FQ

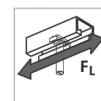

Tracción longitudinal FL

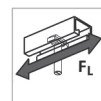

Cargas dinámicas con  
amplitud de carga ΔF



- Torres el faro



- Le Parc Libertador

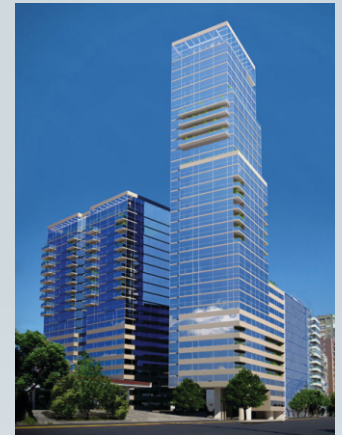

- Odeón



- Torres Mirabilia

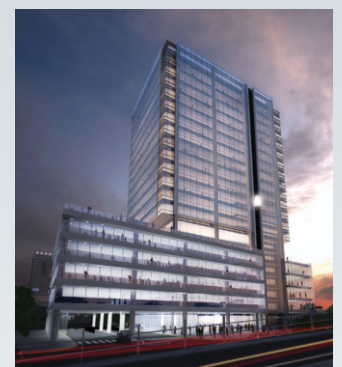

- Sidus



- Quantum Palermo



- Forum Alcorta



- Libertador Mil



☒ Belgrano Office



- Torre Repsol



- Madero Office

